

# GP850 MODULAR PDV SYSTEM GP850 Chassis

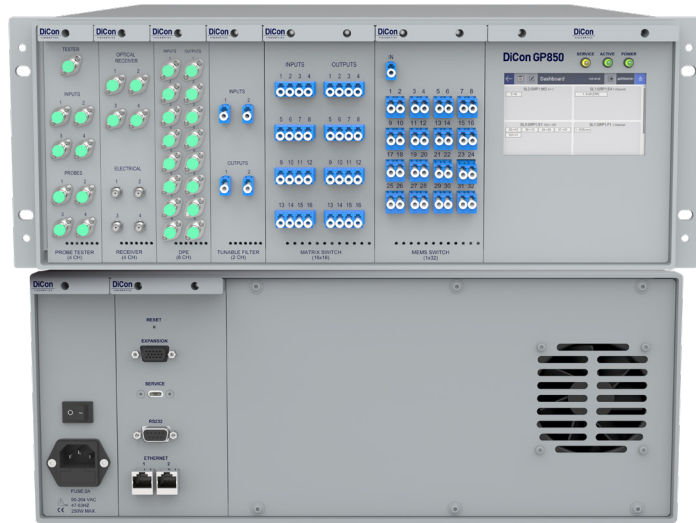

## ORDERING INFORMATION

GP850 -  -  -

Type

**CS** Chassis (Main)  
**EC** Expansion Chassis

PSU

**A1** AC 100-240V Single  
**D1** DC -48V Single  
**A2** AC 100-240V Redundant  
**D2** DC -48V Redundant

Slot Card Location

**F** Front Loading  
**R** Rear Loading

DiCon's **PDV Modular System** is a flexible and user configurable rackmount platform. It integrates many required optical components used in the Photonic Doppler Velocimetry (PDV) technique. The modular chassis is field serviceable and comes with a swappable controller and a swappable power supply. Each system has 8 slots available to house and control a wide array of plug-and-play modules, making the PDVM easy to configure for optimal PDV measurements.

- Plug and Play Modularity
- Intuitive Front Panel
- Ethernet, RS-232, or Web GUI
- Front or Rear Loading Options
- Expandable with Additional Chassis

## OPTICAL SPECIFICATIONS

Fiber Type	9/125 um Single Mode
Wavelength Range	1530 to 1570 nm
Back Reflection	< -50 dB

## CHASSIS SPECIFICATIONS

Chassis Type	19", 4U Extended Rackmount
Plug-In Module Slots	8 per Chassis

## MECHANICAL SPECIFICATIONS

Dimensions in mm

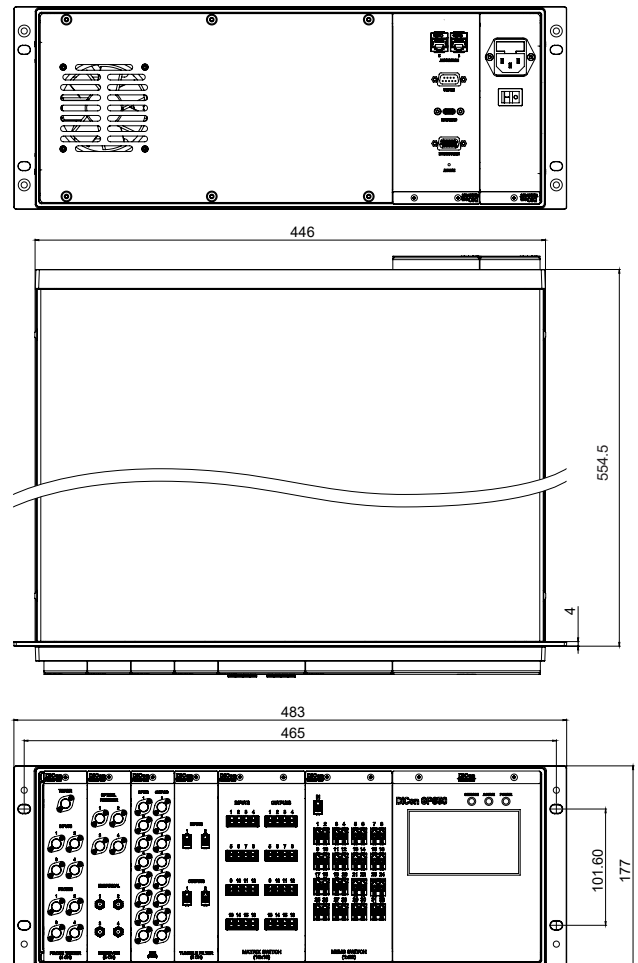

# GP850 PDV Slot Card - Mixer (1 Fiber Probe Per Channel)

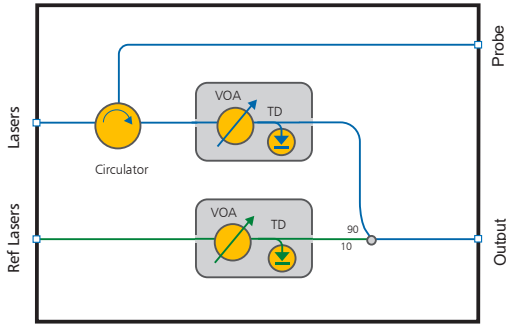

## ORDERING INFORMATION

**GP850 - SL - PDV - MX1 -  -**

No. of Channels

- 1** 1 CH
- 2** 2 CH
- 4** 4 CH

Connector Type

- FC/APC** FC/APC
- LC/APC** LC/APC

Insertion Loss (IL) <sup>1</sup>	Laser to Probe	0.8 dB max.
	Probe to Output	2.8 dB max.
	Ref to Output	11.8 dB max.
Attenuation Range		30 dB min.
Measurable Power Range		-50 to +22 dBm
Input Optical Power		0.5 W max.

1. Test Wavelength at 1550 nm. Measured with 3-jumper method or equivalent. See TIA/EIA 526-7

# GP850 PDV Slot Card - Mixer (2 Fiber Probes Per Channel)

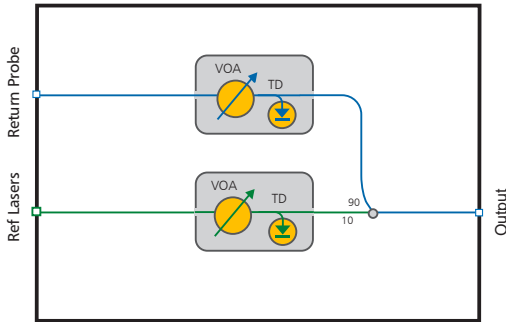

## ORDERING INFORMATION

**GP850 - SL - PDV - MX2 -  -**

No. of Channels

- 1** 1 CH
- 2** 2 CH
- 4** 4 CH

Connector Type

- FC/APC** FC/APC
- LC/APC** LC/APC

Insertion Loss (IL) <sup>1</sup>	Prob to Output	2.0 dB max.
	Ref to Output	11.8 dB max.
Attenuation Range		30 dB min.
Measurable Power Range		-50 to +22 dBm
Input Optical Power		0.5 W max.

1. Test Wavelength at 1550 nm. Measured with 3-jumper method or equivalent. See TIA/EIA 526-7



# GP850 PDV Slot Card - DPE (Dynamic Power Equalizer)

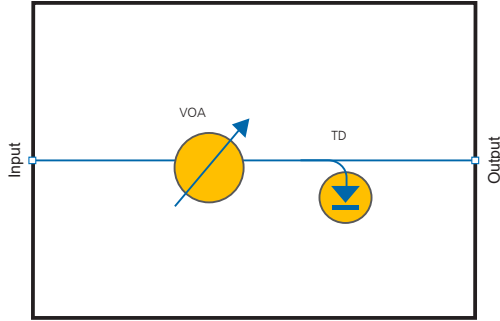

## ORDERING INFORMATION

GP850 - SL - PDV - DPE -  -

No. of Channels

**1** 1 CH  
**2** 2 CH  
**4** 4 CH

Connector Type

**FC/APC** FC/APC  
**LC/APC** LC/APC

Insertion Loss (IL) <sup>1</sup>	0.9 dB max.
Attenuation Range	30 dB min.
Measurable Power Range	-50 to +22 dBm
Input Optical Power	0.5 W max.

1. Test Wavelength at 1550 nm. Measured with 3-jumper method or equivalent.  
 See TIA/EIA 526-7

# GP850 PDV Slot Card - Receiver

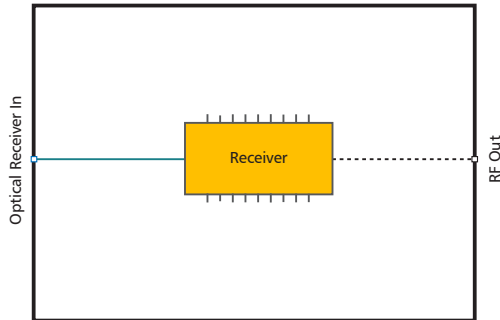

## ORDERING INFORMATION

GP850 - SL - PDV -  -  -

Receiver

**REC25** 25 GHz Receiver  
**REC42** 42 GHz Receiver

No. of Channels

**1** 1 CH  
**2** 2 CH  
**4** 4 CH

Connector Type

**FC/APC** FC/APC  
**LC/APC** LC/APC

Receiver (25 GHz) <sup>1,2</sup>	Thorlabs RX25AF
Receiver (42 GHz) <sup>1</sup>	Thorlabs RX42AF
Optical Input Power	10 dBm max.

1. This assembly operates in a single-ended configuration, using only the non-inverting GPPO output. However, the specification document for Thorlabs' receiver module lists the conversion gain and output swing parameters for differential operation, where both outputs are used. Divide the differential conversion gain and output swing by 2 to determine the single-ended specifications.

2. Peaking Low (PKL) and Peaking High (PKH) are set to float and Gain Control Voltage (GC) is set to 2 V +0.1 V. Contact DiCon for different settings.



# GP850 PDV Slot Card - 1X4 Splitter

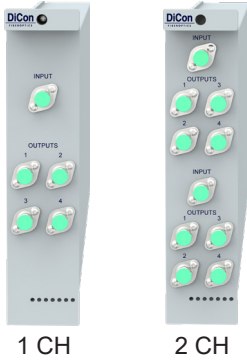
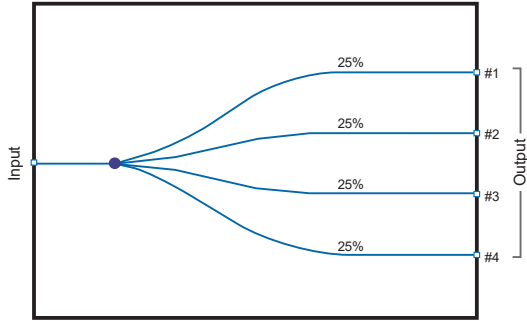

## ORDERING INFORMATION

**GP850 - SL - PDV - SPL4 -  -**

No. of Splitters

**1** 1  
**2** 2

Connector Type

**FC/APC** FC/APC  
**LC/APC** LC/APC

Insertion Loss (IL) <sup>1</sup>	7.0 dB max.
Input Optical Power	2.0 W max.

1. Test Wavelength at 1550 nm. Measured with 3-jumper method or equivalent. See TIA/EIA 526-7

# GP850 PDV Slot Card - 200 GHz ITU Channel 3-Port Mux

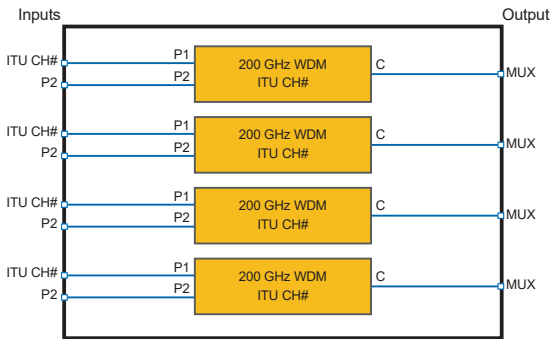

## ORDERING INFORMATION

**GP850 - SL - PDV - FW2 -  -**

200 GHz CH

**X** Specify 200 GHz ITU Channel Number for each of Mux  
*\*Use "/" to add up to 4 individual WDM  
For example: 32/38/40/40*

Connector Type

**FC/APC** FC/APC  
**LC/APC** LC/APC

Insertion Loss (IL) <sup>1</sup>	P1-C	1.3 dB max.
	P2-C	0.6 dB max.
Passband	P1-C	0.5 dB min.
Optical Power		0.5 W max.

1. Test Wavelength at 1550 nm. Measured with 3-jumper method or equivalent. See TIA/EIA 526-7



# GP850 PDV Slot Card - 2X1 Switch

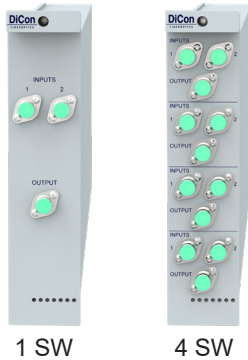
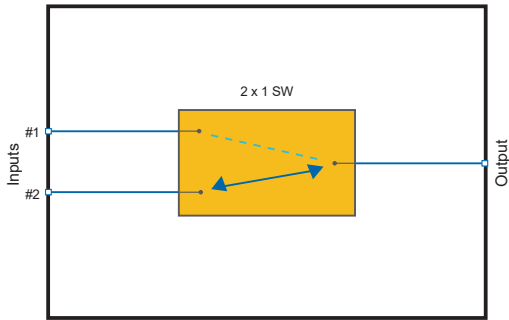

## ORDERING INFORMATION

**GP850 - SL - PDV - MS2X1 -  -**

No. of Switches

<b>1</b>	1
<b>2</b>	2
<b>4</b>	4

Connector Type

<b>FC/APC</b>	FC/APC
<b>LC/APC</b>	LC/APC

Insertion Loss (IL) <sup>1</sup>	0.6 dB max.
Crosstalk / Off State	-50 dB max.
Optical Power	0.5 W max.

1. Test Wavelength at 1550 nm. Measured with 3-jumper method or equivalent.  
See TIA/EIA 526-7

# GP850 PDV Slot Card - MEMS 1X4, 1X8 and 1X12 Switches

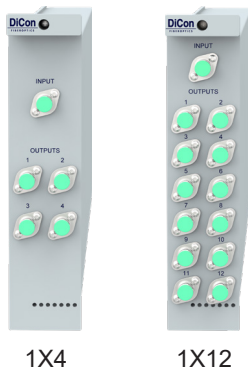
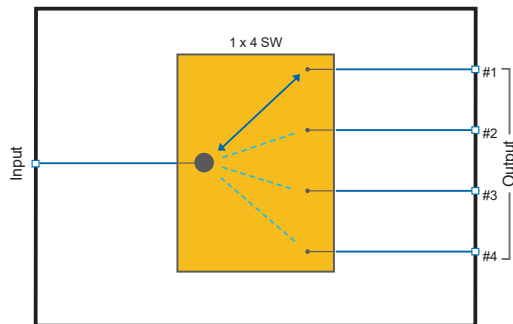

## ORDERING INFORMATION

**GP850 - SL - PDV - MS1X  - 1 -**

No. of Channels

<b>4</b>	1x4
<b>8</b>	1x8
<b>12</b>	1x12

Connector Type

<b>FC/APC</b>	FC/APC
<b>LC/APC</b>	LC/APC

Insertion Loss (IL) <sup>1</sup>	0.8 dB max.
Crosstalk / Off State	-50 dB max.
Optical Power	0.5 W max.

1. Test Wavelength at 1550 nm. Measured with 3-jumper method or equivalent.  
See TIA/EIA 526-7



# GP850 PDV Slot Card - MEMS 8X8 Matrix Switch

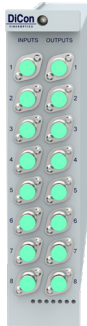
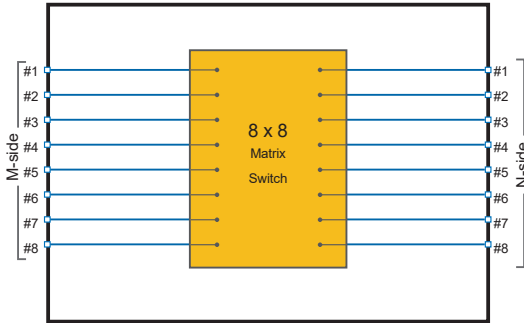

8X8

## ORDERING INFORMATION

**GP850 - SL - PDV - SX8X8 - 1 -**

Connector Type

**FC/APC** FC/APC  
**LC/APC** LC/APC

Insertion Loss (IL) <sup>1</sup>	1.0 dB max.
Input Optical Power	0.5 W max.

1. Test Wavelength at 1550 nm. Measured with 3-jumper method or equivalent.  
 See TIA/EIA 526-7

